

No. 887,569.

PATENTED MAY 12, 1908.

A. J. AUBREY.
AUTOMATIC SHELL EJECTOR FOR FIREARMS.
APPLICATION FILED JAN. 14, 1907.

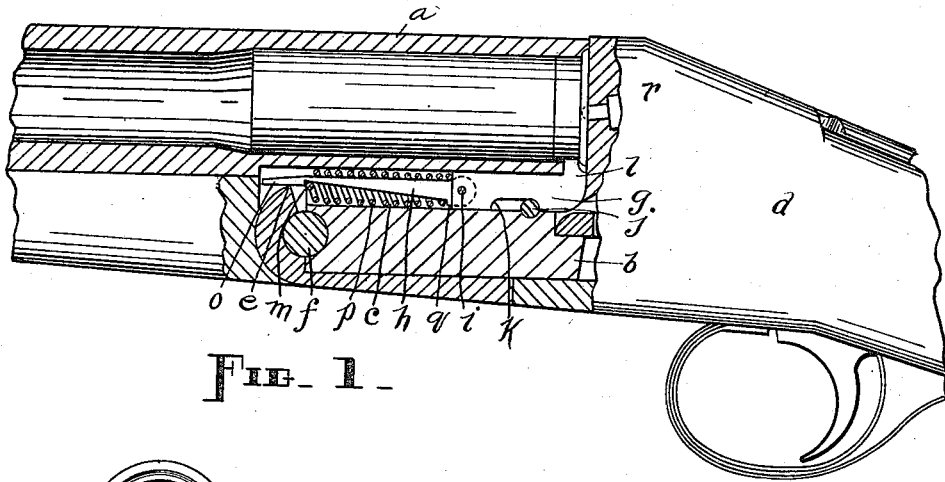

FIG. 1.

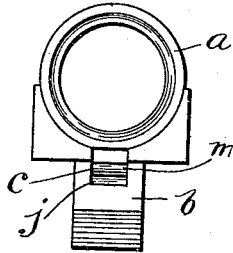

FIG. 4.

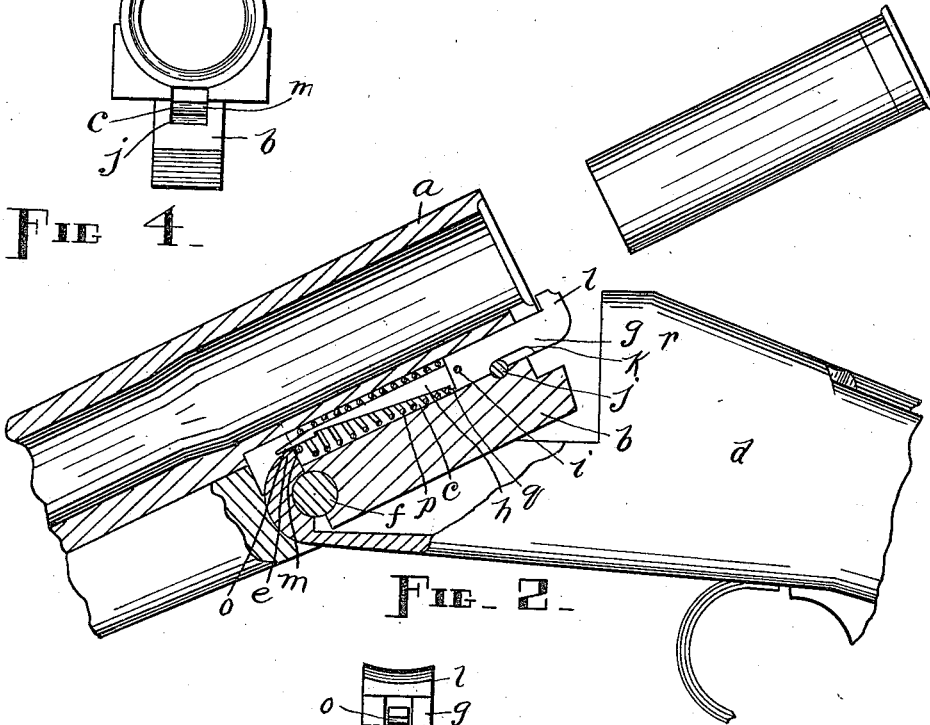

FIG. 2.



FIG. 3.

Witnesses
L. C. Kellogg.
E. M. Sullivan.

Inventor
Albert J. Aubrey
by Alfred P. Fairbanks
his Attorney

UNITED STATES PATENT OFFICE.

ALBERT J. AUBREY, OF MERIDEN, CONNECTICUT.

AUTOMATIC SHELL-EJECTOR FOR FIREARMS.

No. 887,569.

Specification of Letters Patent.

Patented May 12, 1908.

Application filed January 14, 1907. Serial No. 352,147.

To all whom it may concern:

Be it known that I, ALBERT J. AUBREY, a citizen of the United States of America, residing at Meriden, in the county of New Haven and State of Connecticut, have invented a new and useful Automatic Shell-Ejector for Firearms, of which the following is a specification.

My invention relates to improvements in shell ejectors and lugs for firearms and consists essentially of an ejector block having a pivotally attached locking and releasing hook, a spring arranged to hold said hook in locking engagement with a fixed member and to actuate said block when the hook is released from said member by the "breaking" of the gun, said parts being located in the locking lug on the barrel. The said ejector block is preferably made square, however I do not wish to be understood as limiting myself to such a construction as other shapes may be used without departing from the spirit of the invention. For the aforesaid square construction of the ejector block I have provided a lug having an angular slot therein suitable to contain the said ejector, all as hereinafter set forth.

The objects of my invention are, first, to provide an ejector which will throw a shell entirely free from the barrel of a gun; second, to provide one which will operate smoothly yet without the play permitted by the ordinary ejecting devices; third, to provide a comparatively simple shell ejector which is strong and durable and consists of few parts which are unlikely to get out of order; fourth, to provide means for forcing the ejector block into its proper position when the gun is closed, for fastening the block in such position, and for releasing and actuating the block when the gun is broken; and, fifth, to provide an inexpensive lug containing an angular slot for a shell ejector.

I attain these objects by the means illustrated in the accompanying drawings in which—

Figure 1 is a vertical section of that part of the gun containing the ejector, with a shell in the barrel, showing the gun closed and said ejector in its normal position, Fig. 2 a similar section showing the gun open or broken and the shell ejected by the released ejector, Fig. 3 an enlarged detail front view of the ejector, and Fig. 4 a detail end view of the lug and barrel.

Similar letters refer to similar parts throughout the several views.

a represents the breech of the barrel, and *b* the locking lug which has a longitudinally extending slot *c* suitable to and containing the ejecting device.

d is the frame and *e* the forward part of the frame which is pivotally connected with the locking lug at *f*.

I provide an ejector block *g* and a hook *h* pivoted at one end at *i* to said hook. Both the ejector block *g* and the hook *h* are located in the locking lug slot *c*, said block being arranged to slide therein within the limits determined by a pin *j* set into the locking lug and partly lying above the bottom of the slot *c* and by the ends of a transverse slot *k* in the under side of the block *g*. The ejector block *g* is constructed with a head *l* which is curved on the upper edge to correspond with the inner curve of the barrel *a*.

The hook *h* is pivoted to the ejector block *g* as stated above and has a projection adapted to engage and when in its normal position engaging the pin *m*, which latter extends transversely across the locking lug slot *c* above the pivot *f*. The end *o* of the hook *h* is of such length that, when the device is thrown outward to eject a shell, the under surface will always be in contact with the pin *m* and thus prevented from assuming an inoperative position.

A spiral spring *p* encircles the hook *h* and bears at one end against the pin *m* and at the other end against the shoulder *q* on the bottom of the heel of said hook.

It will now be seen that, when the parts are normally disposed as when the gun is closed, said spring *p* presses the hook into engagement with the pin *m* and retains it in such engagement, but when the hook is forced out of engagement with said pin, in the manner presently to be described, said spring at once acts upon the ejector block and thrusts it outward, as far as the pin *j* will permit, with sufficient force and shock not only to dislodge the shell but throw the same clear of the barrel. Thus the spring *p* serves the double purpose of always pressing the hook *h* into contact with the pin *m* and into engagement with said pin when the gun is closed and of actuating the ejector block when the gun is broken and the hook *h* released from the pin *m*.

Having described the several parts of my

shell ejector I will now explain their operation: When the gun is closed the head 1 of the ejector block *g* is contacted by the breech block *r* and forced inward with the hook *h* 5 against the resiliency of the spring *p* which forces said hook into engagement with the pin *m*. When the gun is broken the end *o* of the hook *h* rides up on the frame *e* and is thus forced out of engagement with the pin *m*. 10 The spring *p* then actuates the ejector block *g*, as far as permitted by the pin *j* with such force and suddenness as to throw the shell entirely free from the barrel. This operation is so regulated or timed that the ejector block 15 will not be actuated or shot until the barrel reaches such an angle that the shell will clear the breech block as it is ejected.

As stated above the ejector block *g* is preferably made square, however, I do not wish 20 to be understood as limiting myself to such a construction as other shapes may be used without departing from the spirit of the invention. To contain the aforesaid square ejector block I provide a lug *b* having therein 25 an angular slot *c* as shown in Fig. 4. Heretofore lugs having angular slots for shell ejectors have not been used on account of the expense of drilling such slots but in my construction this objection is overcome by the 30 slot being made at the same time the upper side of the lug is milled to fit the barrel. The said lug *b* is constructed with a longitudinally running angular slot *c* opening through the top thereof. The breech of the 35 barrel *a* is planed on the under side and thus closes the open side of the said slot *c* with a flat surface when the lug *b* is brazed or otherwise fastened thereto.

What I claim as my invention and desire 40 to secure by Letters Patent is:—

1. The combination, in a device of the class specified, with a gun barrel and its lug, of an ejector block slidingly mounted in said 45 lug, a locking and releasing member in pivotal connection with said block, a fixed member in the path of said locking and releasing member, and resilient means adapted to retain the locking and releasing member in engaging relation with said fixed member and 50 also to actuate the ejector block upon the releasing of the same.

2. The combination, in a device of the class specified, with a gun barrel and its lug, of an ejector block slidingly mounted in said 55 lug, a hook pivoted at one end to said block, a fixed locking pin for said hook, and resilient

means common to both the block and hook adapted to normally force said hook into engagement with said pin and to actuate the block when released. 60

3. The combination, in a device of the class specified, with a gun barrel and its lug, of an ejector block slidingly mounted in said 65 lug, a hook pivoted at one end to said block and provided with a heel below the longitudinal plane of said pivotal point, a fixed locking pin for said hook, and a spring arranged to bear at one end against said pin and at the other end against said heel of the 70 hook.

4. The combination, in a device of the class specified, with a gun barrel and its lug, of an ejector block slidingly mounted in said 75 lug, a hook provided with a heel pivoted at one end to said block, a fixed locking pin for said hook, a spring arranged to bear at one end against said pin and at the other end against said heel of the hook, and means to limit the outward movement of the ejector 80 block.

5. The combination, in a device of the class specified, with a gun stock and a frame having a hook at its forward end, a gun 85 barrel and its lug, a pivot pin in said frame for said lug and the breech block of a gun, of an ejector block slidingly mounted in said lug and adapted to be forced inward by said breech-block, a locking hook provided with a heel pivoted at one end to said block, a fixed 90 locking pin for said locking hook, a spring arranged to bear at one end against said pin and at the other end against said heel of the locking hook, and means to limit the outward movement of the ejector block, the locking hook being swung on its pivot against 95 the resiliency of said spring out of engagement with its pin by said hook at the forward end of the frame when the gun is broken.

6. The combination of a gun barrel, a lug adapted to be affixed on the under side of 100 said barrel, said lug having a longitudinal and transversely rectangular slot therein opening through the top thereof, the barrel closing the open side of said slot when the parts are assembled, and an ejector rectangular 105 in cross-section slidingly mounted in said slot.

ALBERT J. AUBREY.

Witnesses:

ALFRED B. AUBREY,
ALFRED C. FAIRBANKS.